

- GENERAL NOTES:**
1. Use good components, and this amp will sound great. Use crummy ones, and there's no guarantee.
 2. The amp as shown will put out just over 6 watts RMS into 8 ohms (on the 8 ohm tap). If you change the power supply to deliver 350V instead of 300V, you will get just over 7 watts, and be right at the limit (300V) for plate voltage on the 6B4's.
 3. You can use any output transformer you like, with a primary of between about 5000 and 6600 ohms CT, rated for at least 7 watts. Higher impedances will give you less distortion and less output power. Bigger (15 or 25 watt transformers) will deliver cleaner bass, usually. If the transformer has ultra-linear taps, just tie them off and don't connect them.
 4. If you build a stereo version of the amp, you need separate filament windings for each channel, as the output tube bias is present on the filament winding, and you don't want to connect both channels together.
 5. Use matched output tubes for minimum distortion.
 6. Capacitor values in general are not critical. Coupling caps can be anything between 0.1uF and 1uF, at least 300V. Paper/oil or polypropylene are best, 716P orange drops work well. Power supply caps can be Elna, Black Gate, LCR, or whatever you like. Do not exceed 50uF at the front of the choke or you will exceed the peak current ability of the rectifier tube. The output capacitor can be made larger if you wish; it will reduce hum a little. Don't leave out the polypro caps on the input stage.
 7. Resistors should be within 5% of the indicated values, wattages at least what's shown. Carbon comp, metal film, or your favorite audiophile neurotic resistor is fine.
 8. Tubes: I used Sovtek 6B4G's. They sound great, cost little, and in this circuit have lasted over two years so far with no degradation. Use your favorite 6SN7 or 5692 (I've used GE and Sylvania NOS). Rectifier can be 5U4 (Russian is OK), or if you can find them GZ37's are better.

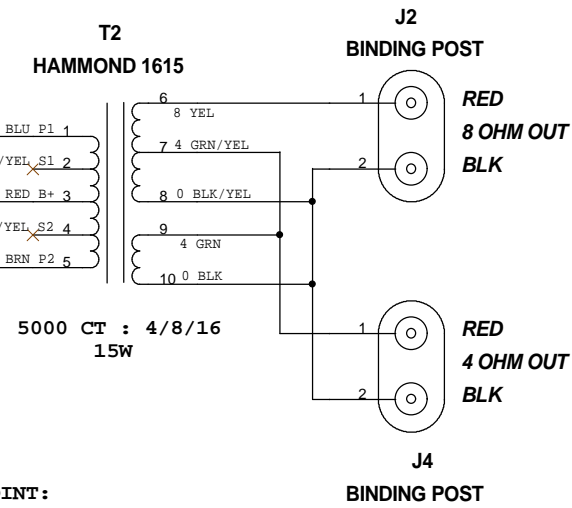

A=14
 VO=+/-4.6, MAX=+96/-52V
 VI=+/-0.29V = 200mV RMS

A=0.88
 VO=+/-4.1, MAX=+45/-25V
 VI=+/-4.6 = 3.3V RMS

A=11
 VO=+/-45, MAX=+/-69V
 VI=+/-4.1, MAX=5.25

A=120mA (30mA EACH)

6B4G Q POINT:
 VA = 250V (295V B+ - 45V VG)
 IC = 60MA PER TUBE
 VG = -45V
 PA = 15W PER TUBE

OUTPUT POWER = 6W CLASS A

PLACE ONE RESISTOR AT EACH 6B4G FILAMENT PIN

Pete Millett - Wheatfield Audio LLC		
Title 6B4G P-P AMPLIFIER		
Size	Document Number	Rev A
Date:	Monday, February 07, 2005	Sheet 1 of 1