

McIntosh

C 26

PREAMPLIFIER



SERVICE INFORMATION

STARTING WITH SERIAL NO. 10P01

McINTOSH LABORATORY INC. 2 CHAMBERS STREET BINGHAMTON, NEW YORK

C 26

ELECTRICAL SPECIFICATIONS

FREQUENCY RESPONSE

+0 to -0.5dB from 20Hz to 20,000Hz

DISTORTION

Less than 0.1% at 2.5 volts output, 20Hz to 20,000Hz

INPUT SENSITIVITY (phono 1 and phono 2)

2 millivolts for 2.5 volts output at 1kHz

INPUT SENSITIVITY (aux, tape 1, tape 2, tuner)

0.25 volts for 2.5 volts output

HUM AND NOISE (phono 1 and phono 2)

74dB below rated output for a 10 millivolt input signal

HUM AND NOISE (aux, tape 1, tape 2, tuner)

85dB below rated output

OUTPUT (main)

2.5 volts with rated input. Up to 10 volts can be developed without distortion.

OUTPUT (tape)

0.25 volts with rated input. Phono input signal of 10 millivolts produces 1.2 volts output.

OUTPUT (center channel)

2.5 volts with rated input on both channels. A level control adjusts output from -6dB to +6dB with respect to main output.

BASS CONTROL

-20dB to +16dB at 20Hz

TREBLE CONTROL

+20dB at 20,000Hz

LF FILTER

Flat or roll off below 50Hz, down 12dB at 20Hz

HF FILTER

Flat or roll off above 5,000Hz, down 12dB at 20,000Hz

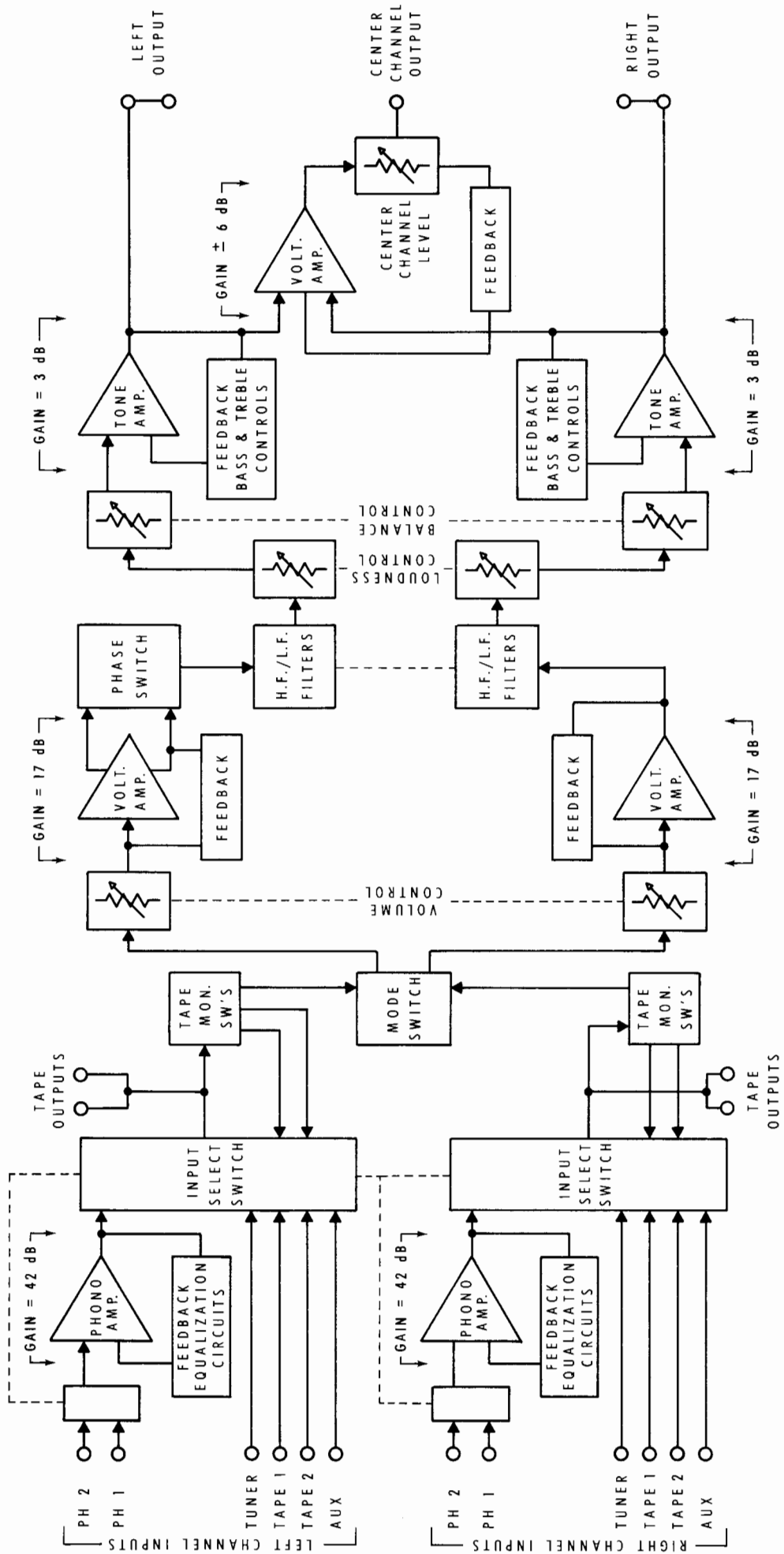

C 26 BLOCK DIAGRAM

SCHEMATIC NOTES

1. Unless otherwise specified: Resistance values are in ohms, 1/4 watts, and 10% tolerance; capacitance values smaller than 1 are in microfarads (μF); capacitance values greater than 1 are in picofarads (pF); inductors are in microhenries (μH).
2. Printed circuit board components are outlined on the schematics by dotted lines. The circled numbers around the dotted lines correspond to the numbers on the PC Board layouts.
3. The heavy lines on the schematics denote the primary signal path.
4. The terminal numbering of rotary switches is for reference only.
5. All voltages indicated on the schematics are measured under the following conditions:
 - a. Use of an 11 megohm input impedance VTVM.
 - b. All voltages $\pm 10\%$ with respect to chassis ground.
 - c. No signal at input terminals.
 - d. AC input at 117 volts, 50/60Hz.
 - e. Front panel controls at:

Volume	Fully CCW, but with power switch on
Mode	Stereo
Input Selector	Phono 1
Loudness	Flat

 All other controls at normal positions.
6. R313 is 1K in early units.
7. In units with serial No's below 30P55, C309 and C310 are not used.
8. In units with serial No's below 30P50, R127 and R128 are not used.
9. In units with serial No's below 30P53, R129 and R130 are not used.
10. In units with serial No's below AG3301; C3, C4, C13 & C14 are used; C48, C49, C50, C51, C52 C53, R131 & R132 are not used; R129 & R130 are 1M.
11. In units with serial No's below AG1222; R25 & R26 are 1.8K.

**POWER SUPPLY AND CENTER CHANNEL SECTION
PRINTED CIRCUIT BOARD 043-789**

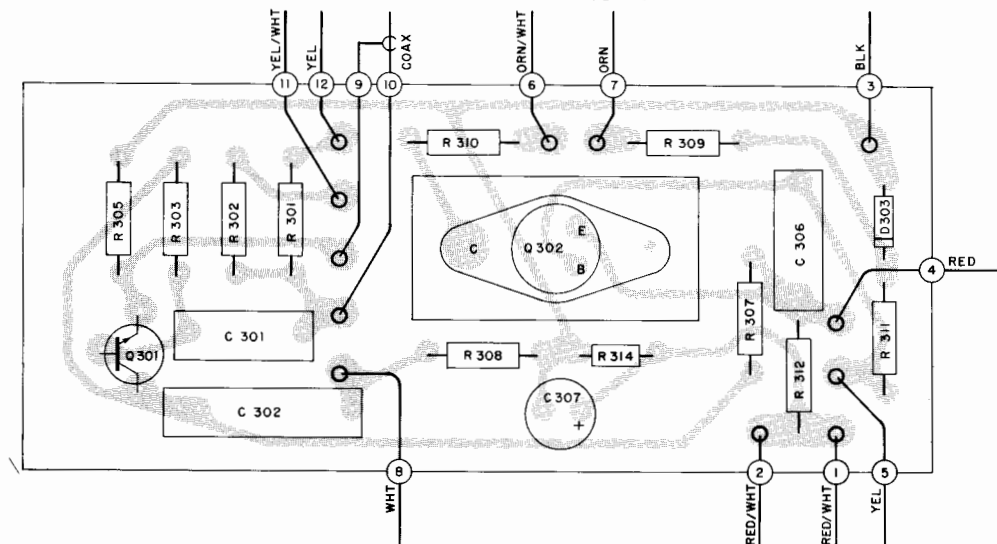

PRINTED CIRCUIT BOARD
043-789

CENTER CHANNEL

POWER SUPPLY

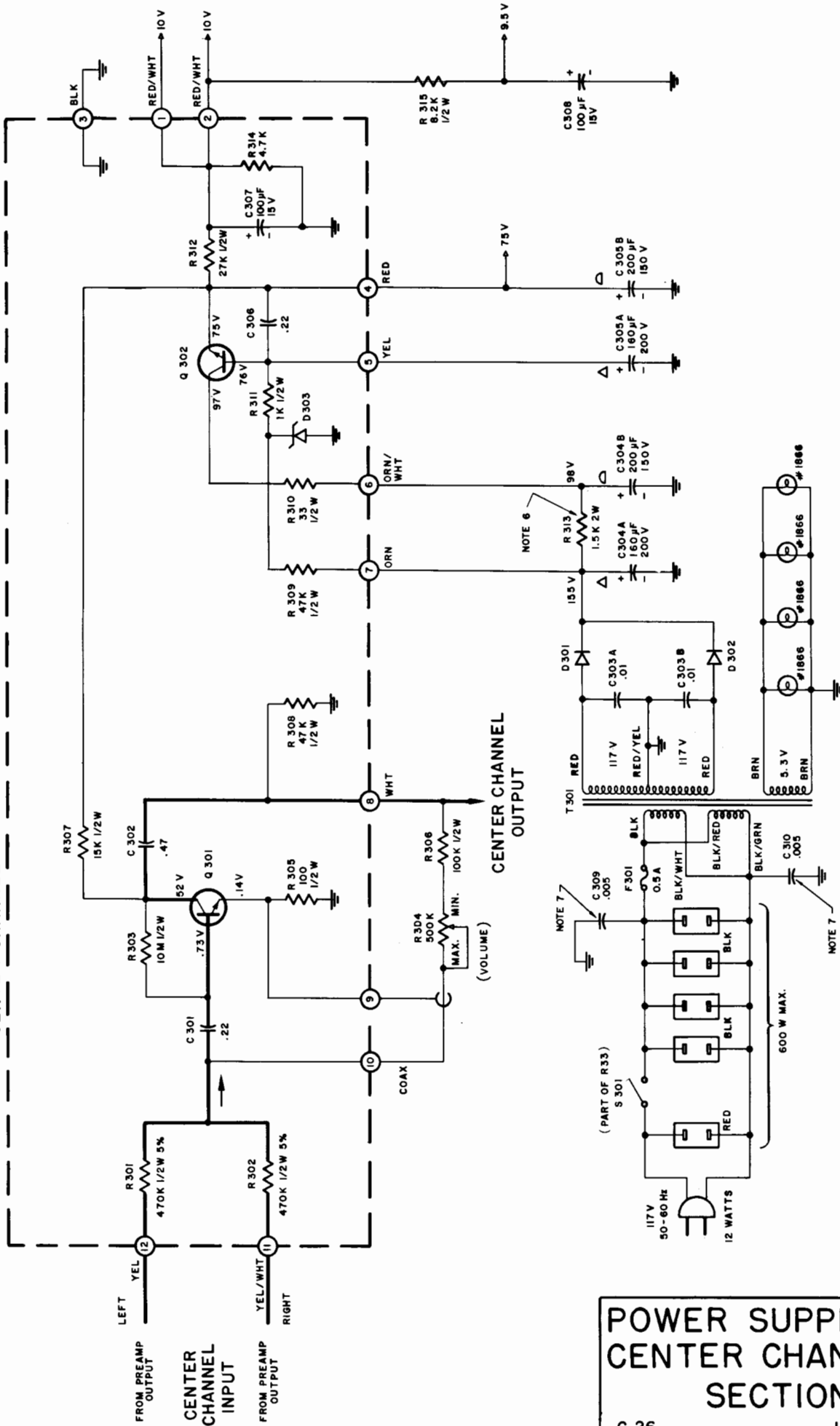

POWER SUPPLY &
CENTER CHANNEL
SECTION

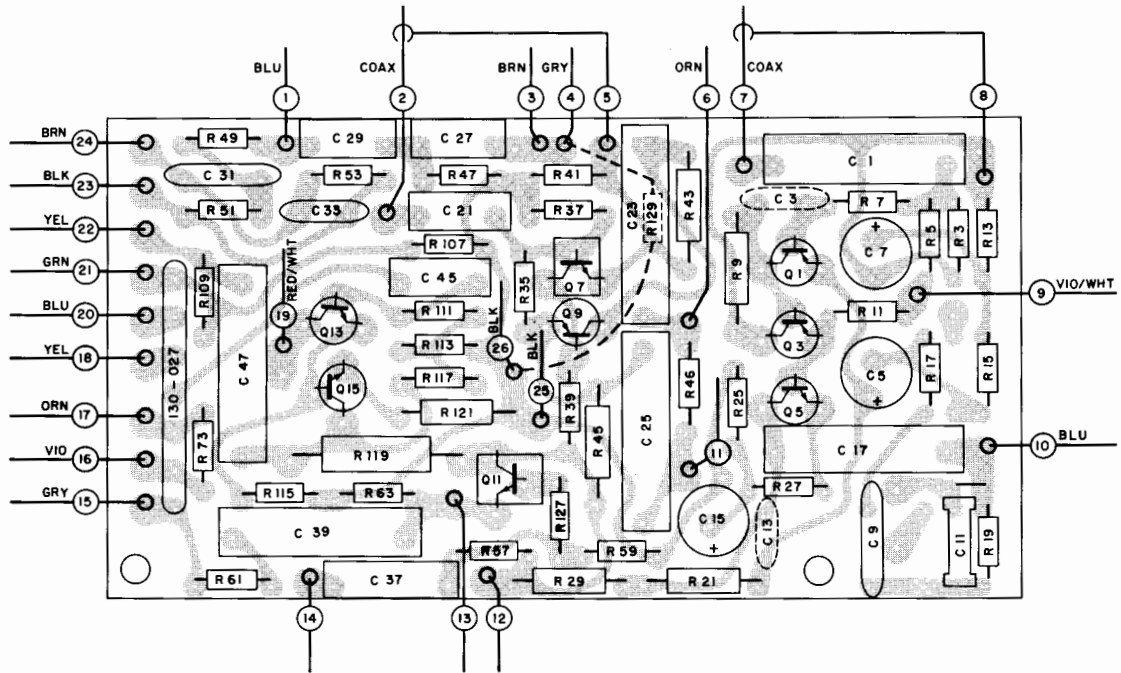

LEFT CHANNEL PREAMP PRINTED CIRCUIT BOARD 044-554

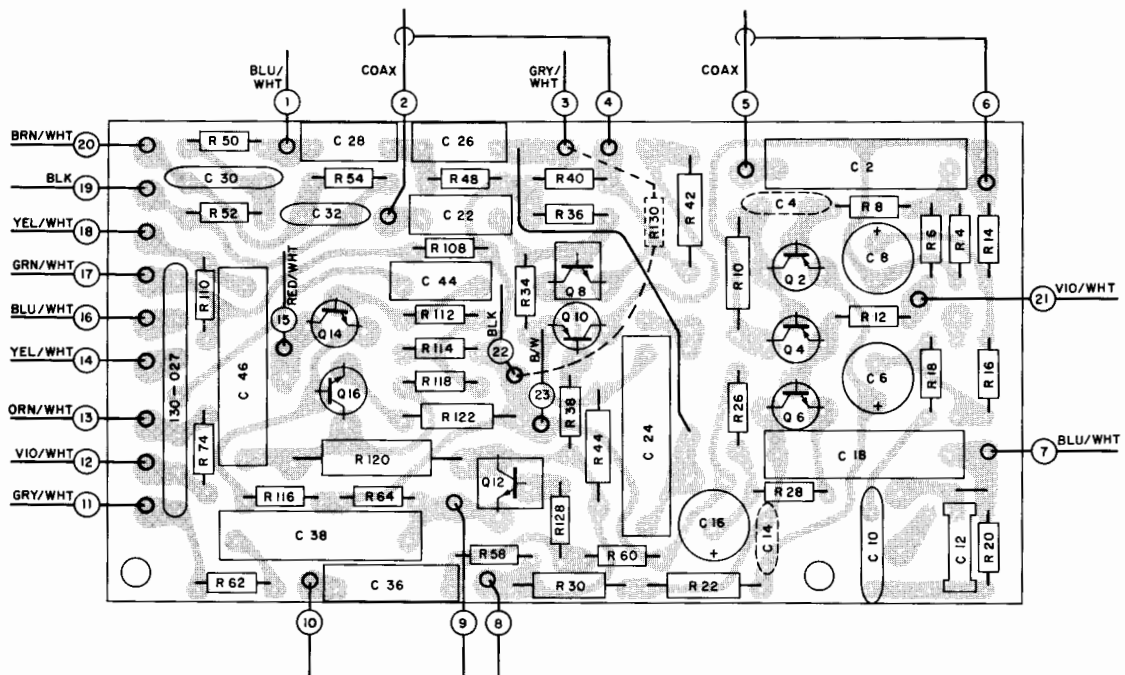

RIGHT CHANNEL PREAMP PRINTED CIRCUIT BOARD 044-553

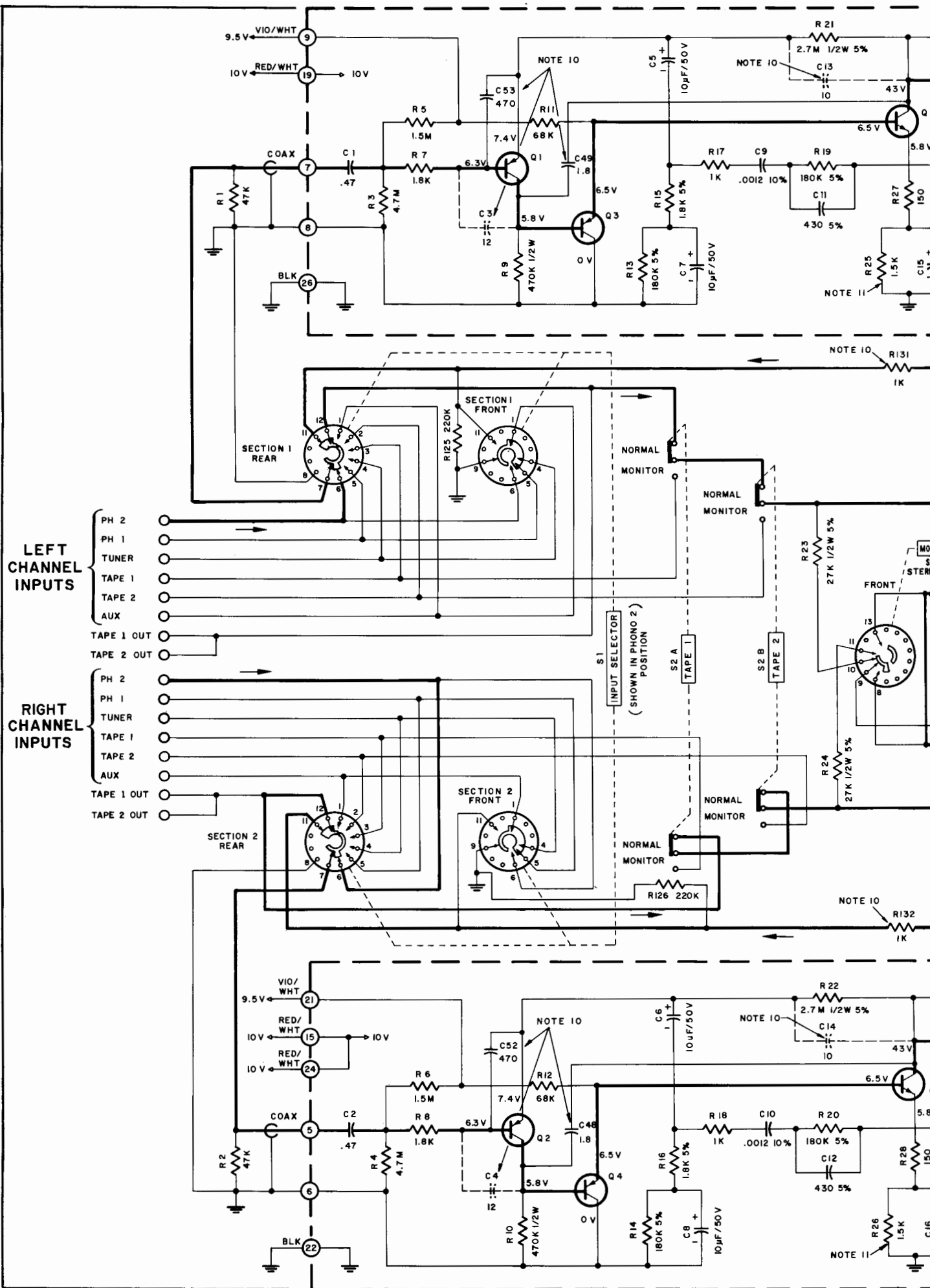

LEFT CHANNEL PREAMP SECTION PRINTED CIRCUIT BOARD 044-554

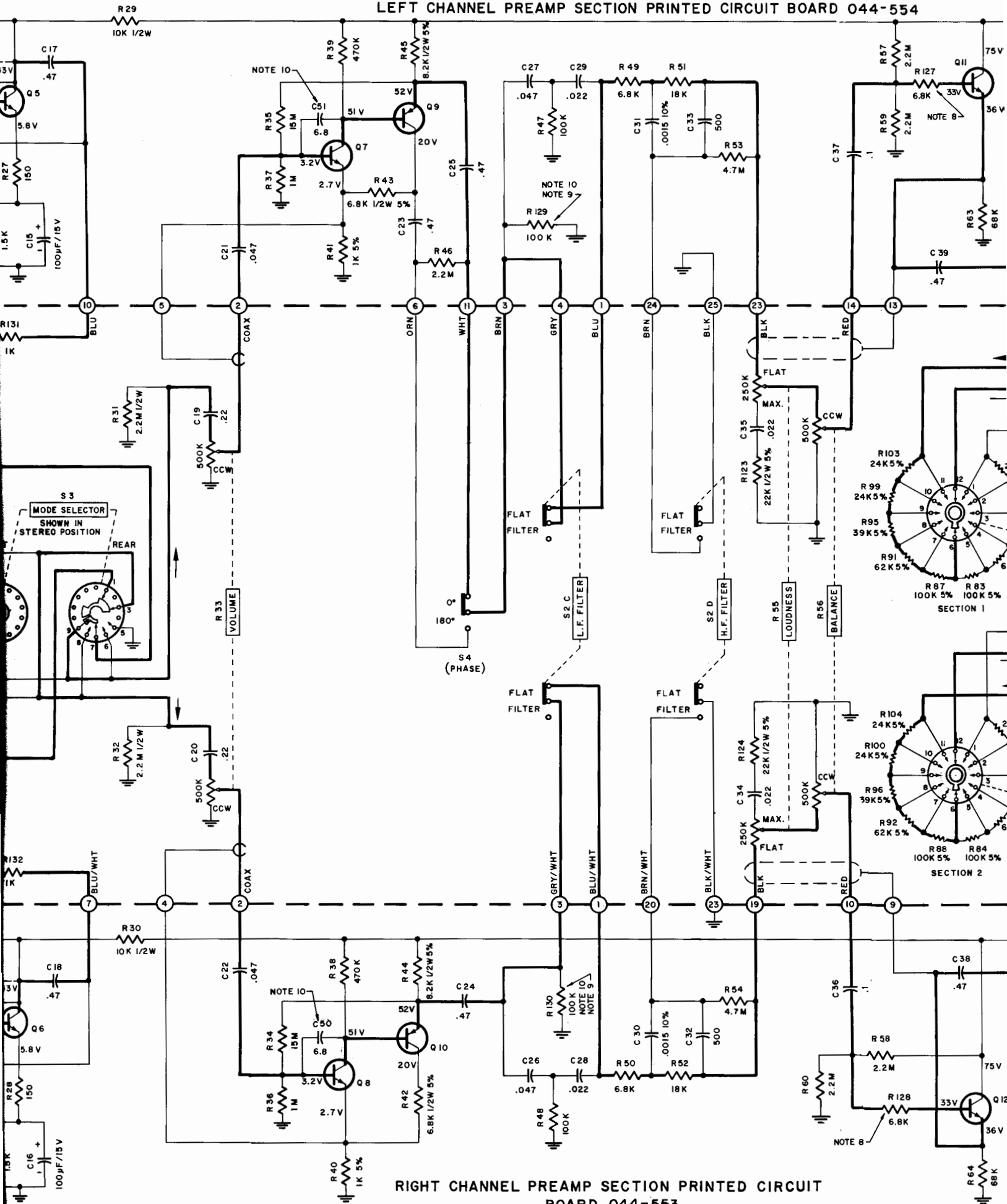

RIGHT CHANNEL PREAMP SECTION PRINTED CIRCUIT BOARD 044-553



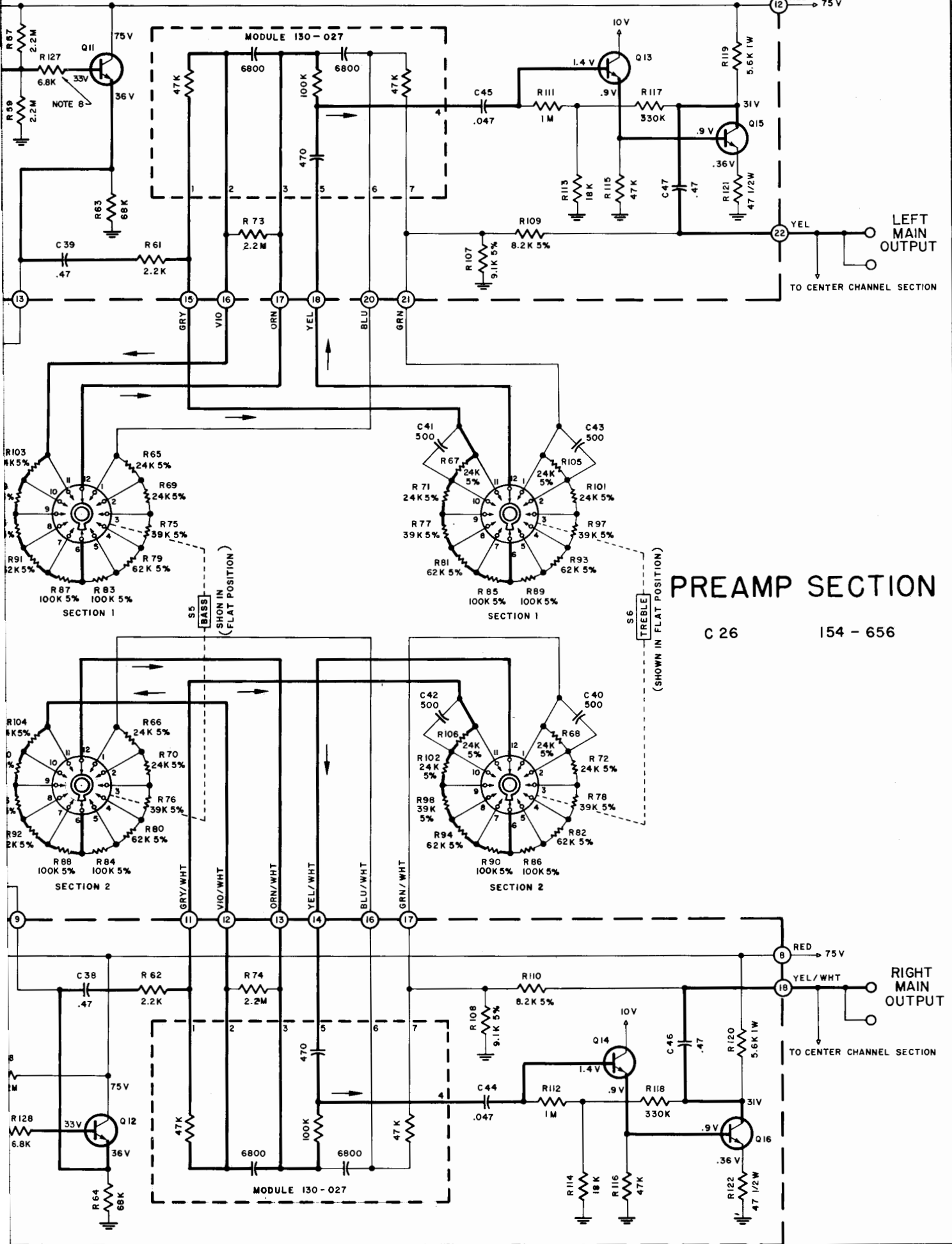

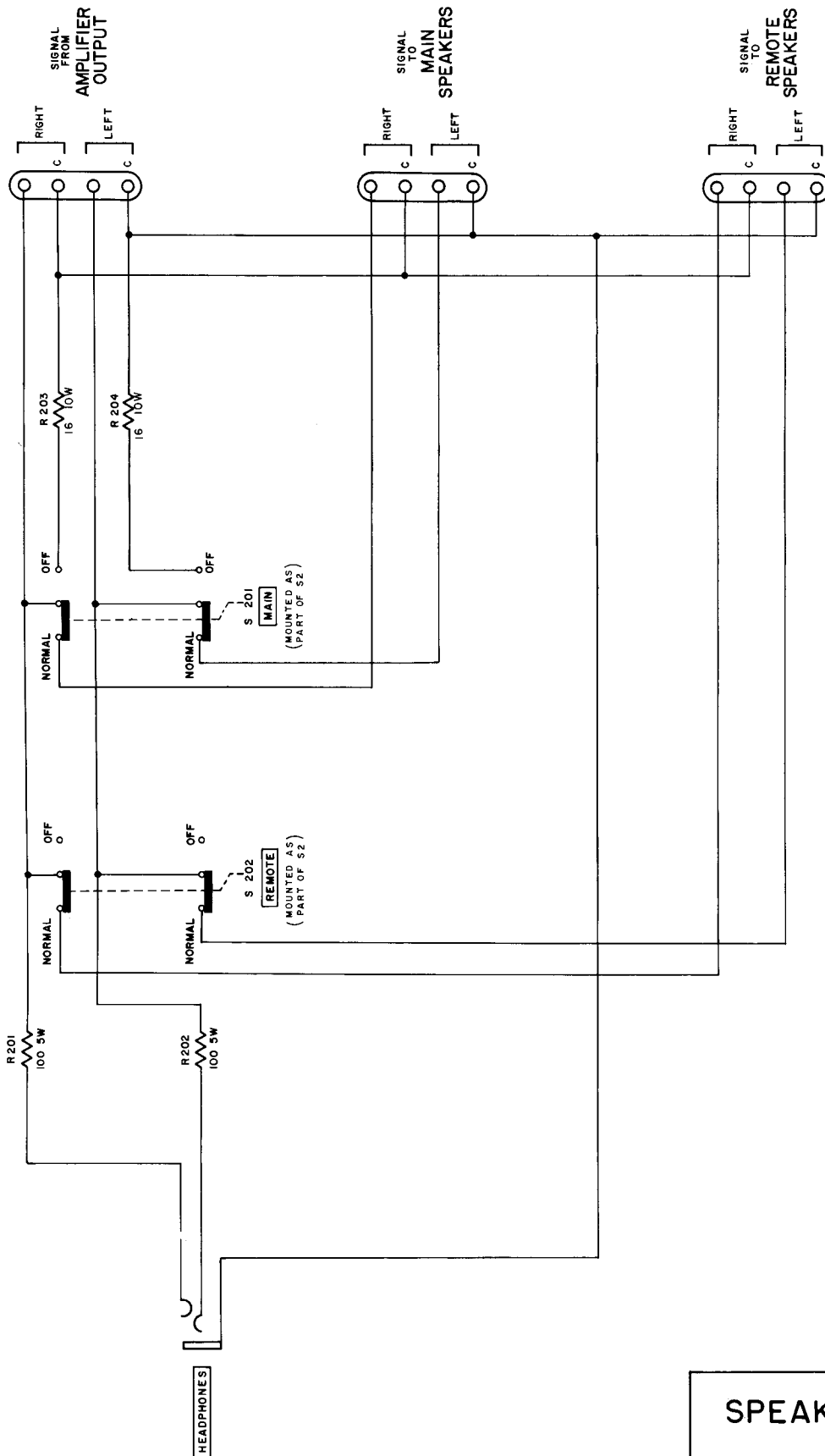

SPEAKER SWITCHING SECTION

C26

154-342

All parts available from
Replacement by PART

- Symbol Number
- C1,2
 - C5,6
 - C7,8
 - C15,16
 - C17,18
 - C19,20
 - C21,22
 - C23,24
 - C25
 - C26,27
 - C28,29
 - C34,35
 - C36,37
 - C38,39
 - C44,45
 - C46,47
 - C301
 - C302
 - C304
 - C305
 - C306
 - C307
 - C308
 - D301,302
 - D303
 - F301
 - Q1,2
 - Q3,4
 - Q5,6
 - Q7,8
 - Q9,10

REPLACEMENT PARTS

All parts not listed are common items obtainable from radio parts jobbers.

Replacement parts may be obtained when ordered by PART NUMBER from:

McIntosh Laboratory, Inc.
Customer Service Department
2 Chambers Street
Binghamton, New York 13903
(telephone 607-723-3512)

Symbol Number	CAPACITORS			Part Number
	Description			
C1,2	Mylar	.47 μ F	250V	064-069
C5,6	Elect.	10 μ F	35V	066-239
C7,8	Elect.	10 μ F	35V	066-239
C15,16	Elect.	100 μ F	16V	066-226
C17,18	Mylar	.47 μ F	250V	064-069
C19,20	Mylar	.22 μ F	200V	064-087
C21,22	Mylar	.047 μ F	250V	064-066
C23,24	Mylar	.47 μ F	250V	064-069
C25	Mylar	.47 μ F	250V	064-069
C26,27	Mylar	.047 μ F	250V	064-066
C28,29	Mylar	.022 μ F	250V	064-065
C34,35	Mylar	.022 μ F	250V	064-064
C36,37	Mylar	.1 μ F	250V	064-067
C38,39	Mylar	.47 μ F	250V	064-069
C44,45	Mylar	.047 μ F	250V	064-066
C46,47	Mylar	.47 μ F	250V	064-069
C301	Mylar	.22 μ F	250V	064-068
C302	Mylar	.47 μ F	250V	064-069
C304	Elect.	160/200 μ F 200/150V		066-095
C305	Elect.	160/200 μ F 200/150V		066-095
C306	Mylar	.22 μ F	250V	064-068
C307	Elect.	100 μ F	16V	066-226
C308	Elect.	100 μ F	16V	066-227
DIODES				
D301,302	Si. rectifier			070-031
D303	Zener diode 75V			070-025
FUSES				
F301	Fuse 1/2 ampere			089-009
TRANSISTORS				
Q1,2	Si. PNP transistor			132-096
Q3,4	Si. PNP transistor			132-096
Q5,6	Si. NPN transistor			132-095
Q7,8	Si. NPN transistor			132-095
Q9,10	Si. PNP transistor			132-096

Q11,12	Si. NPN transistor	132-095
Q13,14	Si. NPN transistor	132-092
Q15,16	Si. NPN transistor	132-042
Q301	Si. NPN transistor	132-095
Q302	Si. NPN transistor	132-028

POTENTIOMETERS

R33	Volume control	134-200
R55	Loudness control	134-199
R56	Balance control	134-198
R304	Center channel level	134-196

RESISTORS

R201,202	Wirewound	100 Ω	10%	5W	139-008
R203,204	Wirewound	16 Ω	10%	20W	139-022

SWITCHES

S1	Input selector switch	146-121
S2	Pushbutton switch	150-006
S3	Mode selector switch	146-122
S4	Phase control switch	146-119
S5	Bass switch	146-123
S6	Treble switch	146-123
S201,202	Speaker switch	148-025

TRANSFORMERS

T301	Power transformer	043-786
------	-------------------	---------

MODULES

	Tone control	130-027
--	--------------	---------

LAMPS

	#1866 (front panel)	058-014
--	---------------------	---------

FRONT PANEL AND TRIM

	Front panel	043-784
	Front panel end caps	018-120
	Volume control knob	044-372
	Balance control knob	044-372
	Loudness control knob	044-372
	Mode selector knob	044-372
	Input selector knob	044-372
	Treble knob (rear)	090-009
	Treble knob (front)	044-374
	Bass knob (rear)	090-009
	Bass knob (front)	044-374
	Phase knob	044-373
	Center channel knob	044-373

Plastic Pushbutton	017-128
--------------------	---------

MOUNTING SYSTEM

Shelf bracket (right)	043-592
-----------------------	---------

Shelf bracket (left)	043-593
----------------------	---------

Mounting template #100	038-179
------------------------	---------

Hardware package	043-792
------------------	---------

MISCELLANEOUS ITEMS

Line cord	170-021
-----------	---------

Fuseholder	178-001
------------	---------

Shipping carton	043-946
-----------------	---------

Owners manual	038-867
---------------	---------

Plastic feet	017-041
--------------	---------

Shorting plug	127-001
---------------	---------

Push terminal (outputs)	074-030
-------------------------	---------

Audio cable (6')	170-015
------------------	---------

McIntosh SERVICE BULLETIN

LOW FREQUENCY FILTER SWITCH MODIFICATION

MODEL: C 26 Preamp

PURPOSE OF MODIFICATION: To eliminate a "popping" sound when the low frequency filter switch is depressed.

WHAT UNITS ARE AFFECTED: Serial No. 10P01 to 30P52 Only.

WHEN MODIFICATION SHOULD BE MADE: When the customer specifically mentions the noise or when any other service is performed on the unit.

McINTOSH MODIFICATION KIT NO.: No kit available.

PARTS REQUIRED:

Quantity	Part Number	Description
2	136-236	1 meg, 10%, 1/2W Resistor

PROCEDURE:

- Step 1 Remove bottom cover.
- Step 2 Add 1 resistor to the bottom side of each PC board as shown. The parts appear as R129 and R130 on the drawing.

(over)

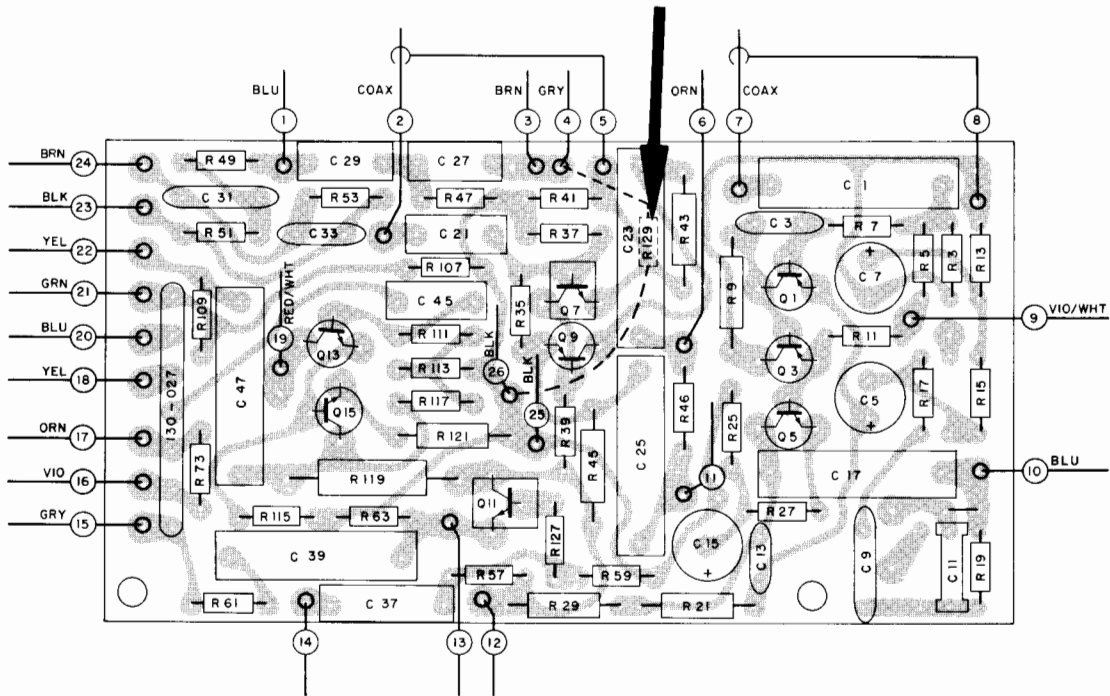

LEFT CHANNEL PREAMP PRINTED CIRCUIT BOARD 043-991

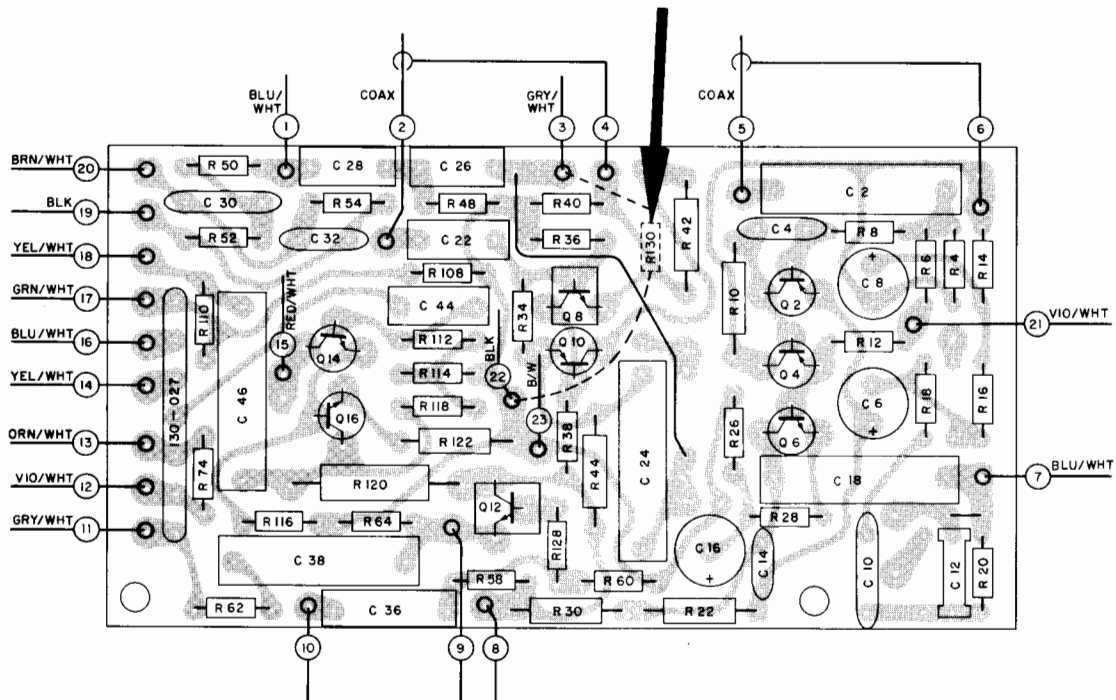

RIGHT CHANNEL PREAMP PRINTED CIRCUIT BOARD 043-992

REDUCE RF INTERFERENCE

MODEL: C 26 Preamplifier

PURPOSE OF MODIFICATION: To reduce sensitivity to RF-interference.

WHAT UNITS ARE AFFECTED: All units with Serial Numbers below AG3301

WHEN MODIFICATION SHOULD BE MADE: Whenever a customer complains of undesired reception of CB and HAM-apparatus, when the unit is operating in the Phono Mode-also when interference from man-made noise is encountered, such as: Refridgerators, passing cars, etc.

PARTS REQUIRED:

QUANTITY	PART NUMBER	DESCRIPTION
2	136301	Res. = 100K, 1/4W, 10% R399,400
2	061002	Disc. Cap. = 1.8pF, \pm .25pF NPO
2	061008	Disc. Cap. = 6.8pF, 20% NPO
2	061032	Disc. Cap. = 470pF, 20%
2	136296	Res. = 1K, 1/4W, 10%

PROCEDURE: This change has to be made on both left and right PC board 043091 and 043092.

- Discard: C302, 304 = 061010 = Disc. Cap. 12pF
C313, 314 = 061009 = Disc. Cap. 10pF
R399, 400 = 136303 = Comp. Res. 1M
- Connect a 061032 = 470pF capacitor between the base and the emitter of transistor Q301, 302.

(OVER)

3. Connect a 061002 = 1.8pF capacitor from the collector of transistor Q301, 302 to the collector of transistor Q305, 306.
4. Connect a 061008 = 6.8pF capacitor from the base of transistor Q307, 308 to the collector of transistor Q307, 308.
5. Replace R399 (R400) with a 136301 = 100K resistor.
6. Add a 1000 ohm resistor (136296) in series with the blue lead that connects to pin #10 on the left preamp board. This resistor should connect directly to pin #10 and the end of the blue lead. Using leads no longer than necessary, do the same for the blue/white lead connecting to pin #7 on the right preamp board.

